

# HS1V H02 SERIES

## Current Sensor

### Model Number

HS1V 50 H02  
 HS1V 100 H02  
 HS1V 200 H02  
 HS1V 300 H02  
 HS1V 400 H02  
 HS1V 500 H02  
 HS1V 600 H02

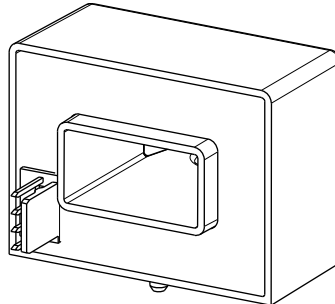

For the electronic measurement of current: DC, AC, pulsed..., with galvanic separation between the primary and the secondary circuits.

### Features

- ✧ Open loop current sensor using the Hall effect
- ✧ Galvanic separation between primary and secondary
- ✧ Insulating plastic case recognized according to UL 94-V0
- ✧ No insertion losses
- ✧ Small size
- ✧ Standards:
  - IEC 60664-1:2020
  - IEC 61800-5-1:2022
  - IEC 62109-1:2010

### Applications

- ✧ AC variable speed
- ✧ Uninterruptible Power Supply (UPS)
- ✧ Static converters for DC motor drives
- ✧ Switch Mode Power Supplies (SMPS)
- ✧ Power supplies for welding applications
- ✧ Battery management
- ✧ Wind energy inverter

## Safety

This sensor must be used according to IEC61800-5-1.

This sensor must be used in electric/electronic equipment with respect to applicable standards and safety requirements in accordance with the following manufacture's operating instructions.

**Caution, risk of electrical shock!**



When operating the sensor, certain parts of the module can carry hazardous voltage (e.g., Primary busbar, power supply). Ignore this warning can lead to injury and/or cause serious damage.

This sensor is a built-in device, whose conducting parts must be inaccessible after installation. A protective housing or additional shield could be used.

Main supply must be able to be disconnected.

# HS1V H02 SERIES

## Absolute maximum ratings(not operating)

Parameter	Symbol	Unit	Value
Supply voltage	$V_C$	V	±15.75
Primary conductor temperature	$T_B$	°C	100
ESD rating, Human Body Model (HBM)	$V_{ESD}$	kV	4

- ※ Stresses above these ratings may cause permanent damage.
- ※ Exposure to absolute maximum ratings for extended periods may degrade reliability.

## Environmental and mechanical characteristics

Parameter	Symbol	Unit	Min	Typ	Max	Comment
Ambient operating temperature	$T_A$	°C	-40		105	
Ambient storage temperature	$T_S$	°C	-40		105	
Mass	$m$	g		60		

## Insulation coordination

Parameter	Symbol	Unit	Value	Comment
Rms voltage for AC insulation test @ 50Hz, 1min	$V_d$	kV	3.6	According to IEC 60664-1
Impulse withstand voltage 1.2/50μs	$V_w$	kV	6.6	According to IEC 60664-1
Clearance (pri.- sec.)	$d_c$	mm	6.3	
Creepage distance (pri.- sec.)	$d_p$	mm	7.3	
Plastic case	-	-	UL94-V0	
Comparative tracking index	$CTI$	PLC	3	
Application example	-	-	300V	Reinforced insulation, according to IEC 61800-5-1, IEC 62109-1CAT III, PD2
Application example	-	-	600V	Basic insulation, according to IEC 61800-5-1, IEC 62109-1CAT III, PD2

# HS1V H02 SERIES

## Electrical data

※ With  $T_A = 25^\circ\text{C}$ ,  $V_C = \pm 15\text{V}$ ,  $R_L = 10\text{k}\Omega$ , unless otherwise noted.

Parameter	Symbol	Unit	Min	Typ	Max	Comment
Primary nominal rms current	$I_{PN}$	A	-50		50	HS1V 50 H02
			-100		100	HS1V 100 H02
			-200		200	HS1V 200 H02
			-300		300	HS1V 300 H02
			-400		400	HS1V 400 H02
			-500		500	HS1V 500 H02
			-600		600	HS1V 600 H02
			Primary current, measuring range*1	$I_{PM}$	A	-150
-300		300				HS1V 100 H02
-600		600				HS1V 200 H02
-900		900				HS1V 300...600 H02
Supply voltage *1	$V_C$	V	$\pm 12$		$\pm 15$	@ 5%
Current consumption	$I_C$	mA		16		
Load resistance	$R_L$	k $\Omega$	10			
Output voltage (Analog) @ $I_{PN}$	$V_{OUT}$	V		$\pm 4.000$		
Electrical offset voltage	$V_{OE}$	mV	-20		20	
Temperature coefficient of $V_{OE}$ *2	$TCV_{OE}$	mV/K	-0.5	$\pm 0.2$	0.5	@ $-40^\circ\text{C} \sim 105^\circ\text{C}$
Theoretical sensitivity	$G_{th}$	mV/A		80.00		HS1V 50 H02
				40.00		HS1V 100 H02
				20.00		HS1V 200 H02
				13.33		HS1V 300 H02
				10.00		HS1V 400 H02
				8.00		HS1V 500 H02
				6.67		HS1V 600 H02
Sensitivity error	$\varepsilon_G$	%	-0.5		0.5	Exclusive of $V_{OE}$
Temperature of G	$TCG$	%/K	-0.05	$\pm 0.02$	0.05	@ $-40^\circ\text{C} \sim 105^\circ\text{C}$
Linearity error 0... $I_{PN}$	$\varepsilon_L$	% of $I_{PN}$	-0.5		0.5	Exclusive of $V_{OE}$
Hysteresis offset voltage @ $I_P=0$ after $1 \times I_{PN}$	$V_{OM}$	mV	-20		20	
Accuracy @ $I_{PN}$	$X$	% of $I_{PN}$	-1		1	Exclusive of $V_{OE}$
Response time @ 90% of $I_{PN}$	$t_r$	$\mu\text{s}$		3	5	
Frequency bandwidth(-3dB)	$BW$	kHz	50			

\*1: If  $I_{PN} \leq 300\text{A}$  and powder supply voltage  $V_C = \pm 12\text{V}$  current sensor, measurement range reduced to 2.5 times  $I_{PN}$ .

# HS1V H02 SERIES

Dimensions (in mm. 1 mm = 0.0394 inch)

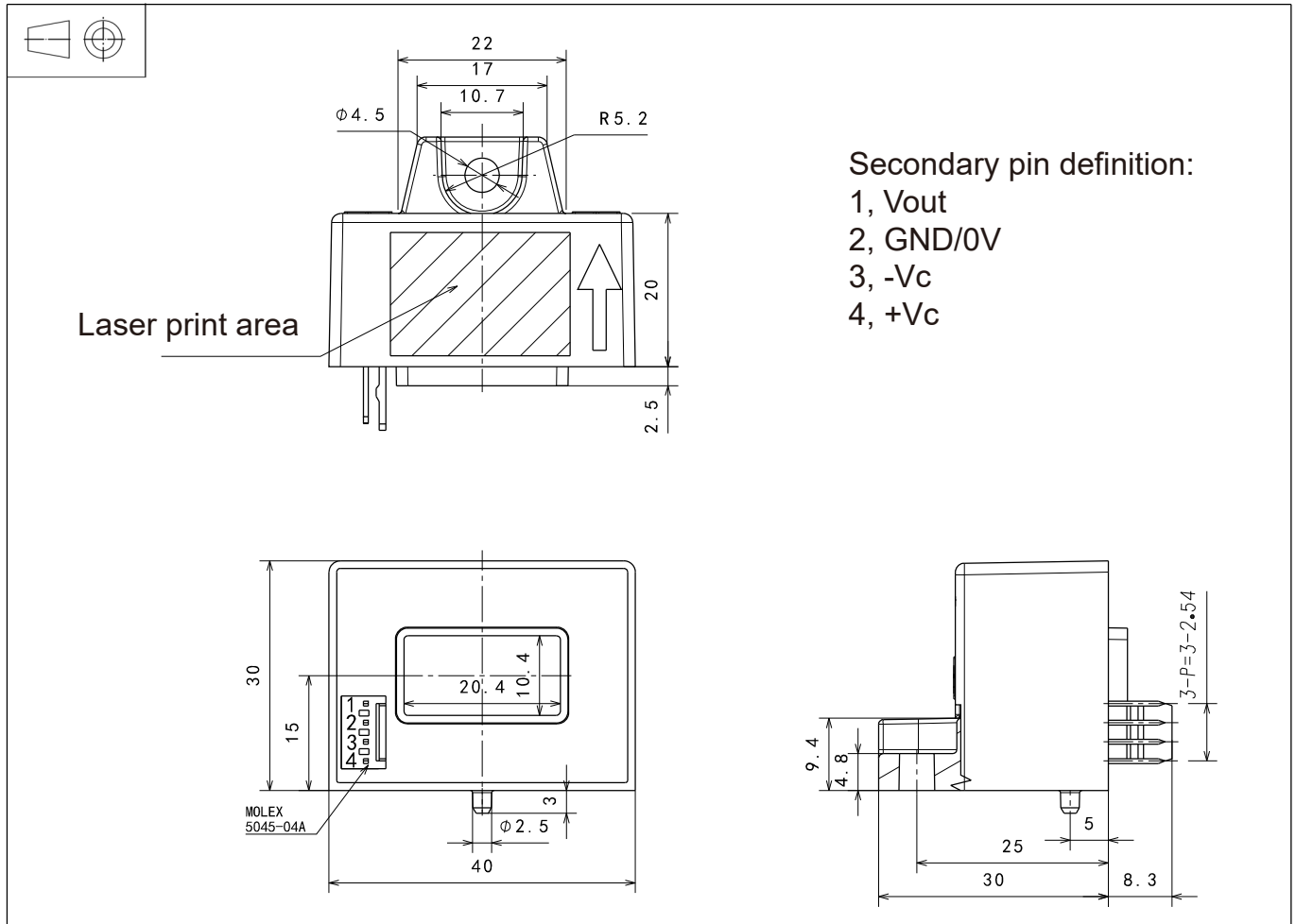

## Mechanical characteristics

- ◇ General tolerance  $\pm 0.5$  mm
- ◇ Connection of secondary Molex 5045-04A
- ◇ Primary hole 20.4mm×10.4mm
- ◇ Sensor 1pc  $\phi 4.5$  mm through hole  
1pc M4 metal screws

Recommended fastening torque 0.9 N•m ( $\pm 10\%$ )

## Remarks

- ◇  $V_{OUT}$  and  $I_P$  are in the same direction, when  $I_P$  flows in the direction of arrow.
- ◇ Temperature of the primary conductor should not exceed 105°C.
- ◇ Dynamic performances (di/dt and response time) are best with a single bar completely filling the primary hole.